

NELLE

Specification Brochure

INNOVATIVE DESIGN

METICULOUS CRAFTSMANSHIP

EXQUISITE MATERIALS



NEFF
BEAUTIFUL LIVING
est. 1966

DEALER
GROWTH
THROUGH
NEFF
INNOVATION

Crafting striking interiors with old-world craftsmanship
and cutting-edge technology.

Idea to Installation

COMPLETE PROCESS

Full Suite

10 Weeks
After Final Processing Sign Off

Efficiency

24 Hours
Quote

Expertise

1 - 2 Weeks
Shop Drawings

Precision

Patented Dry-Fit Process
Stages Product Before Shipping

Accountability

Staging Checklist Certificate
Must Be Signed Internally

Personalized

NEFF's in-house
installation team





Beauty at its truest

EURO- LAMINATES

With industry-leading one-to-one grain reproduction, capture the beauty of exotic wood—without cutting down trees.

REPRODUCE THE LOOK AND FEEL OF REALISTIC WOODGRAIN, CONCRETE, OR MATERIAL DESIGNS

*with enhanced performance benefits
and characteristics.*

Our Eurodekor TFL particleboard is produced by fusing resin-impregnated decor paper directly onto both sides of our Eurospan Particleboard substrate. Heat and pressure activate the resin to effectively seal the substrate.

TFL is appropriate for residential, healthcare, hospitality, retail and other commercial settings.

- Cabinets
- Closet Systems
- Office Furniture
- Store Fixtures
- Architectural Wall Paneling

Your benefits

- A pre-fabricated panel only requiring cutting and edge banding
- Impact and wear
- Fade resistant
- The decor paper is permanently fused to the substrate and won't peel away

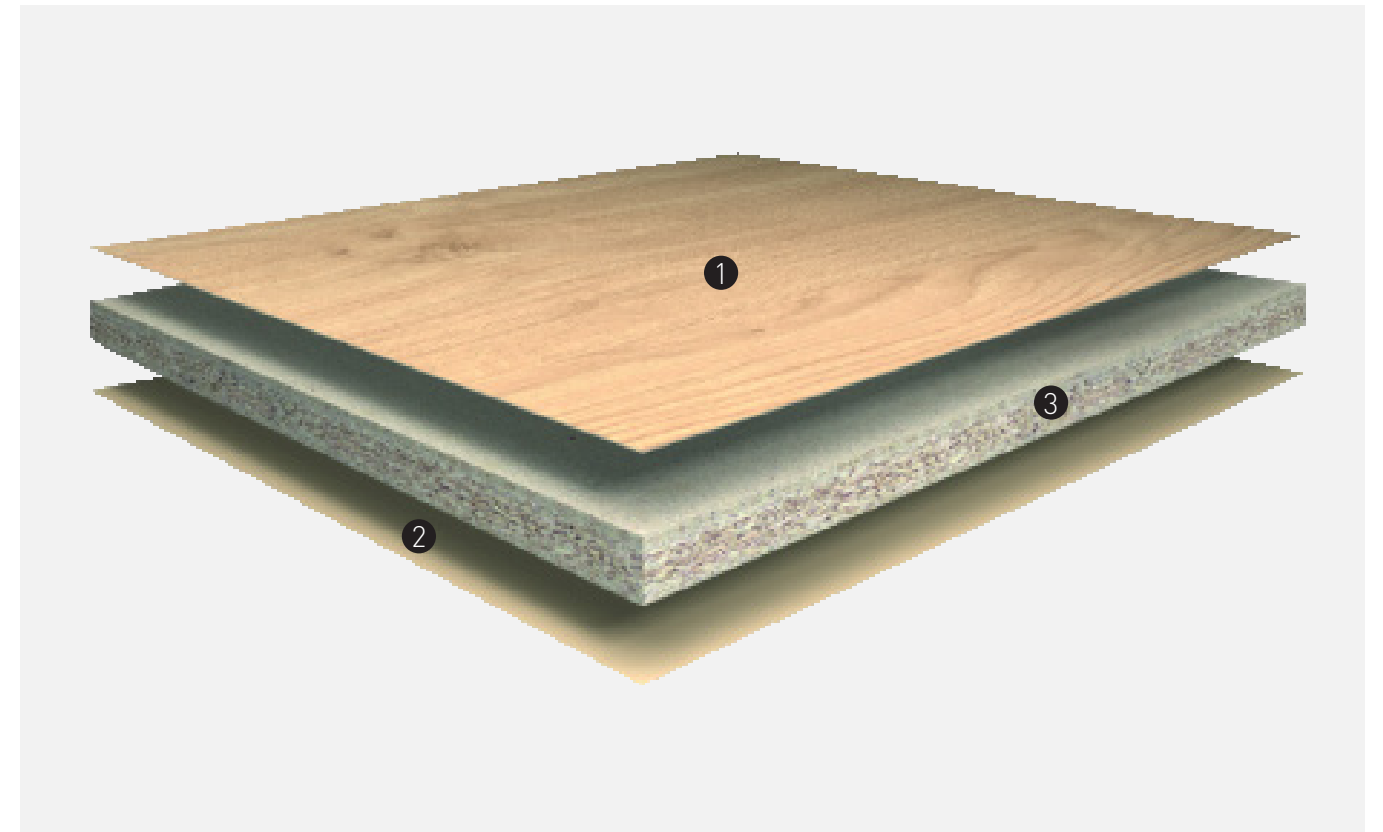

Product construction

1	Melamine resin-impregnated decorative paper
2	Eurospan Particleboard
3	Melamine resin-impregnated decorative paper



CATALYST

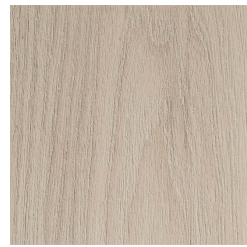

OLMO BIANCO

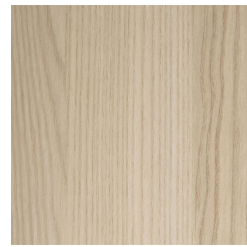

SEYCHELLES



CRIMSON OAK



DRIFTWOOD OAK



LIMED ASH



WEATHERED OAK



BELLEMENT TOUX



HONEY



GOLDKENN



OMAHA TAN OAK

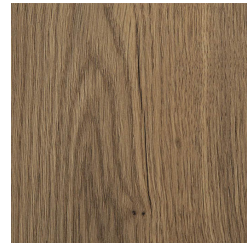

VERMILION OAK

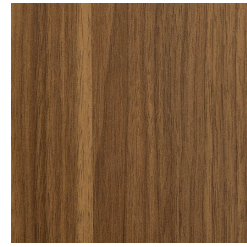

CAMARGUE WALNUT

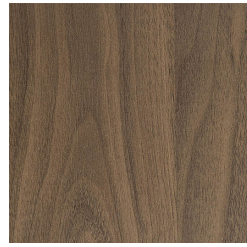

HAZELNUT



EUCALYPTUS

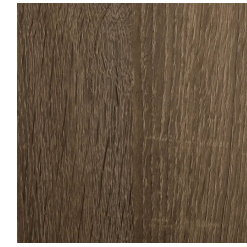

HAVANE TOBACCO



DENVER OAK

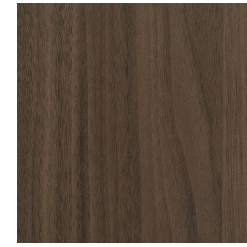

CARINI TRUFFLE



DARK CHOCOLATE



FOX GREY

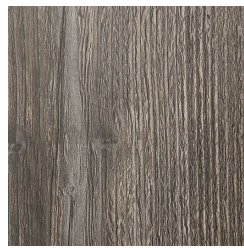

BARN PINE



CARBON

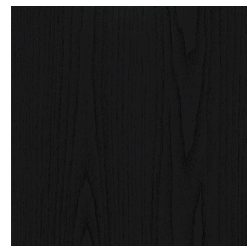

BLACK PINE GRAIN

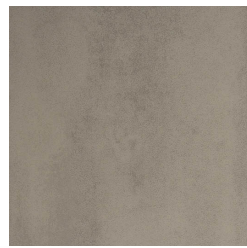

SAFE HOUSE



SLATE



WAXED LINEN



GREY LINEN

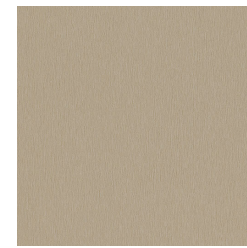

CHAMPAGNE BRASS

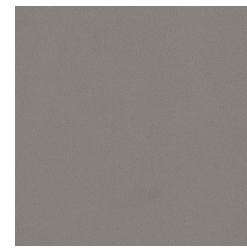

IRON INDIUM

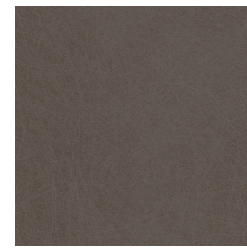

SADDLEBACK STEEL

EURO-LAMINATES \

OUR EURO-LAMINATES ARE IDEAL FOR MID- TO HIGH-TRAFFIC SURFACE AREAS, CURVED APPLICATIONS AND AREAS IN NEED OF POSTFORMING

standard laminates only

Product construction

1.	Overlay (for printed decors)
2.	Impregnated decorative paper
3.	Impregnated Soda kraft paper
4.	Balancer paper

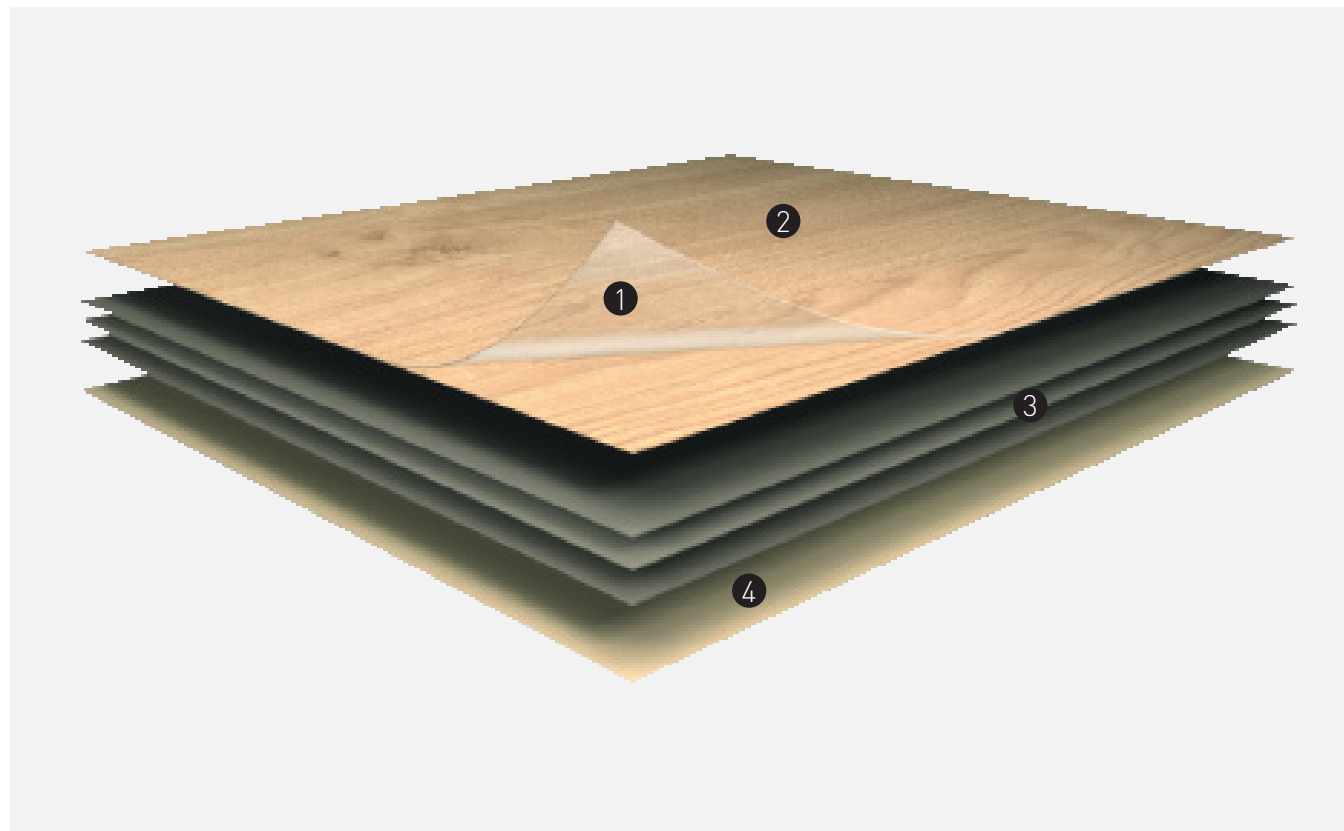

Our laminates offer a multi-layer construction, with a layer of resin-infused decorative paper on the surface and multiple layers of kraft paper in the core. Laminates must be bonded to a substrate, such as particleboard or MDF, during the finishing process.

Laminates are ideal for a variety of residential and commercial applications, such as:

- Tabletops and desktops
- Countertops and backsplash panels
- Cabinets
- Door elements and wall claddings

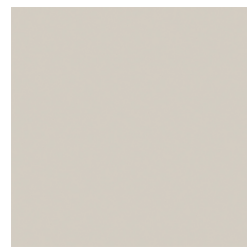

LIGHT GREY



GRAPHITE GREY



BLACKOUT

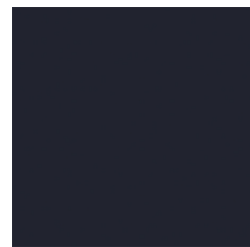

INDIGO BLUE



GREY TEXTILE



WHITE CAPE ELM



WHITE CHROMIX

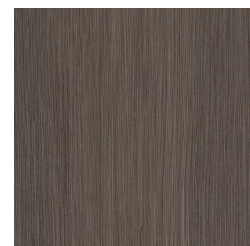

DARK GREY FINELINE

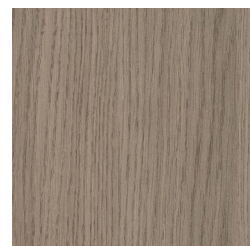

GREY VICENZA OAK

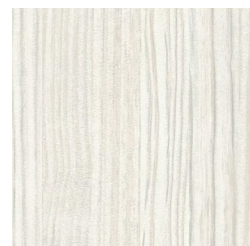

CHALKED OAK

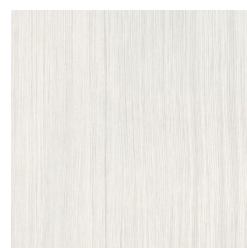

TAHITIAN VANILLA



FABRIC METAL
ANTHRAZIT



FUMO

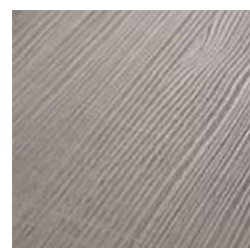

CAUSA DI DANNOGRI



ROBLE JOPLIN

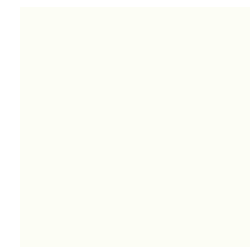

PREMIUM WHITE

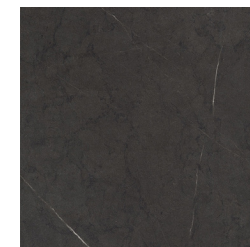

MARMARA MARBLE

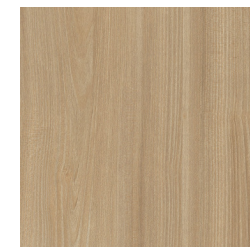

NATURAL TOSSINI ELM



STONE GREY FROZEN
WOOD

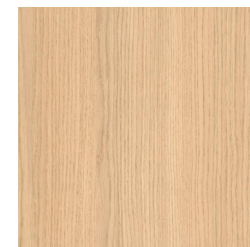

BLEACHED VICENZA OAK



LIGHT NATURAL CASELLA

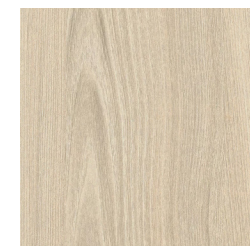

WHITE TOSSINI ELM

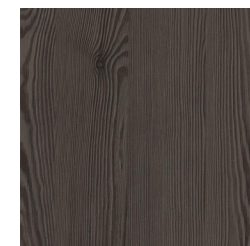

KOJI STAR



TORREFIED OAK



WHITE LINEN



MYSTIC PLOMO

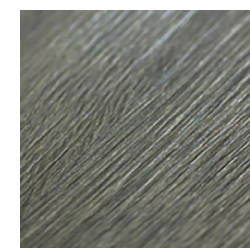

QUERICA

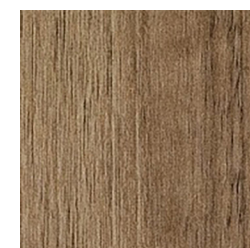

NOGAL SIROKO

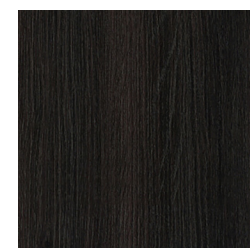

ROBLE SINATRA

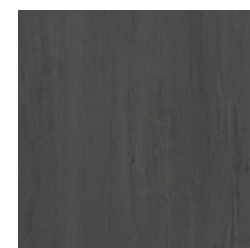

ROBLE AZABACHE

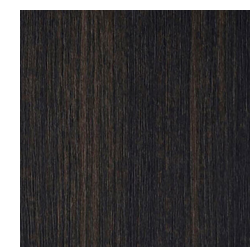

FITTIPALDI



ASCARI



ALPINE WHITE

EURO-LAMINATES \



Elevating the artist's palette

PAINTS

Along with its full palette, NEFF offers bespoke colors and the ability to color match any custom paint.



MIAMI WHITE

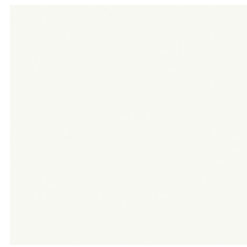

HIGH REFLECTIVE WHITE

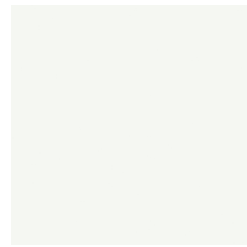

CHANTILLY LACE

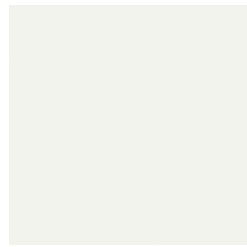

OXFORD WHITE

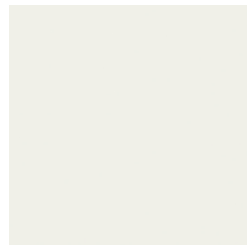

WHITE DOVE

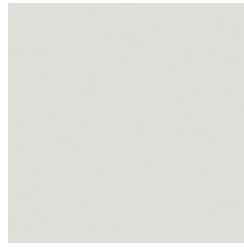

SOLSTICE

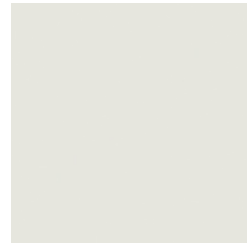

SILVER SATIN

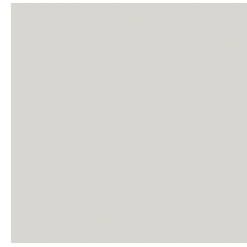

SKIPPING ROCKS

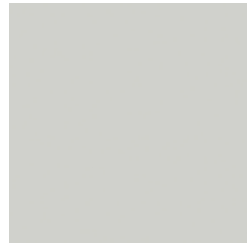

STONINGTON GRAY



COVENTRY GRAY



IRON ORE



CAVIAR



JET BLACK

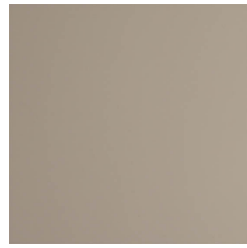

CEMENT

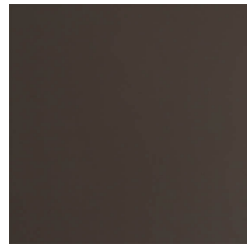

ELEPHANT

PAINTS \



ALEXANDRIA BEIGE

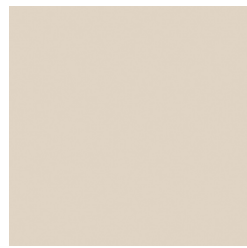

RIVER'S EDGE



RICH CREAM

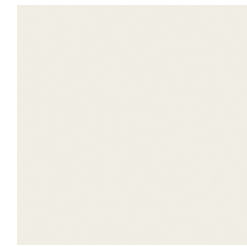

SWISS COFFEE

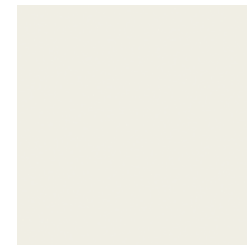

LIGHT FRENCH GRAY



WARM WHITE

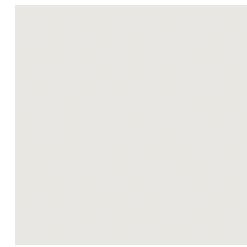

CALM

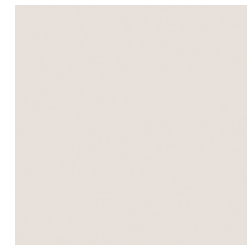

EVERYDAY WHITE



MONORAIL SILVER



SUMMIT GRAY

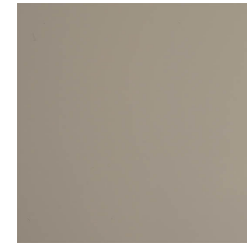

STEEL GRAY



KENDALL CHARCOAL



CRACKED PEPPER



WARM GRAY



BOULEVARD



WHITE SAND



NATURAL LINEN



CARGO PANTS



TAWNY TAN

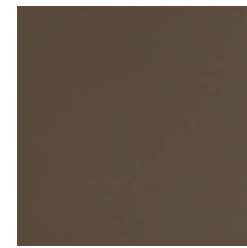

CAFÉ AU LAIT



ROJO MARRÓN

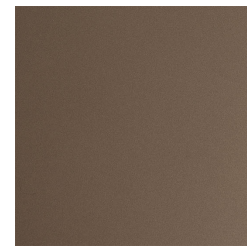

MUD

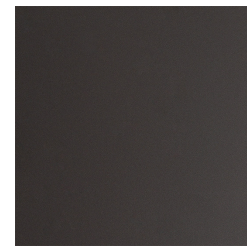

COAL

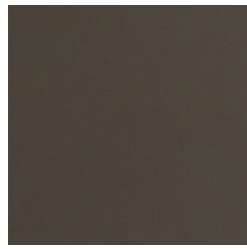

RIVER ROCK

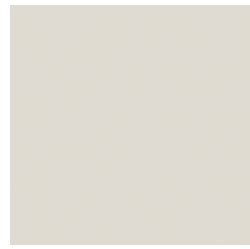

BALBOA MIST



REVERE PEWTER



ZEUS



URBANE BRONZE



ENGLISH BLUE



DOCKSIDE BLUE



WALL STREET



SANTORINI BLUE



PORTUGUESE BLUE

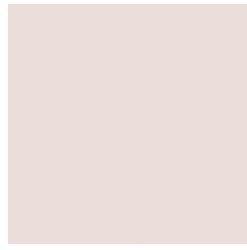

PROPOSAL



PEONY

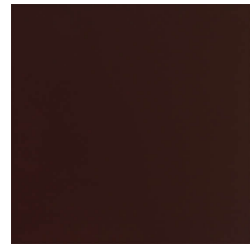

PLUM

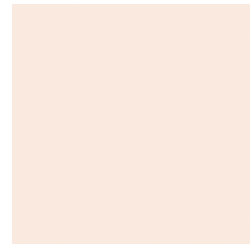

PEACH PARFAIT



DINNER PARTY



SUCCULENT



FOXHALL GREEN



ANDIRON



BLACK EMERALD



WINDCHILL



FRENCH BLUE



HALE NAVY



AFTER THE STORM



LILY LAVENDER



FIG

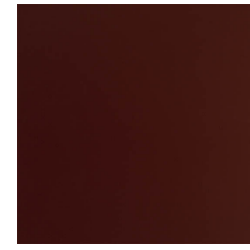

BRICK

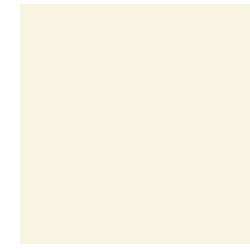

LEMON CHIFFON



HAWTHORNE YELLOW

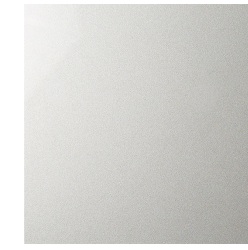

PEARL

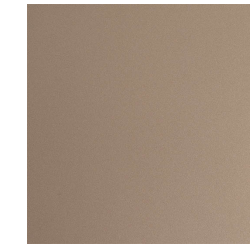

SAND

PAINTS \



Preserving the exotic

VENEERS

Exotic wood species are hand-selected, specific to each project and finished using a state-of-the-art transparent staining process



ANIGRE GROTTTO



BIRDSEYE MAPLE, GROTTTO



ENGLISH SYCAMORE,
NATURAL



MACASSAR EBONY, ETUDE

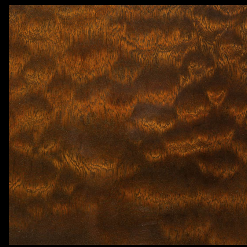

POMMELE SAPELLI, ETUDE



TAN AVODIRE, NATURAL



ELM (FLAT CUT), FLINT

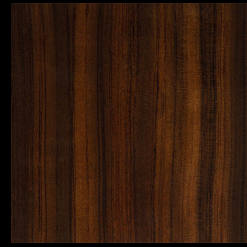

BUGINGA (1/4 CUT),
GROTTTO

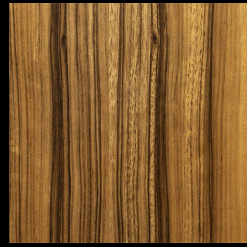

PALDAO (1/4 CUT),
NATURAL



WALNUT (FLAT CUT),
CAMEL

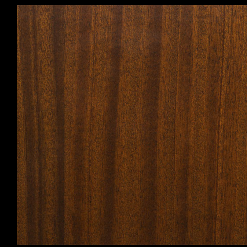

RIBBON MAHOGANY, ETUDE



SMOKED CEREJIERA,
NATURAL

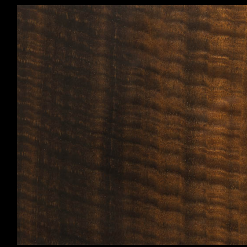

SMOKED EUCALYPTUS,
NATURAL

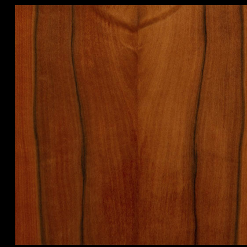

AMERICAN APPLE,
NUTMEG



RIFT OAK WHEAT, FLAT

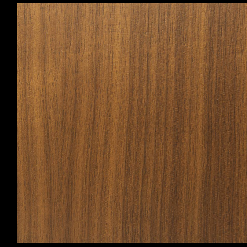

WALNUT (1/4 CUT),
TORTONA

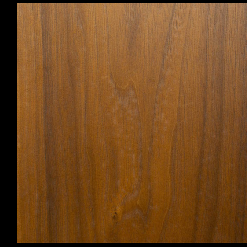

WALNUT (FLAT CUT),
ETUDE

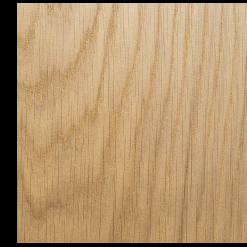

WHITE OAK (FLAT),
HEATHER

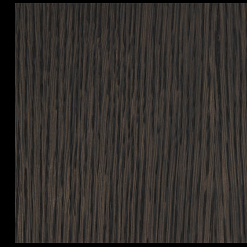

WHITE OAK (RIFT CUT),
GRAPHITE GLAZE



WHITE OAK (RIFT CUT),
TRUFFLE GLAZE



WHITE OAK (RIFT CUT),
WHEAT



BIRDSEYE MAPLE, TUDOR

VENEERS \

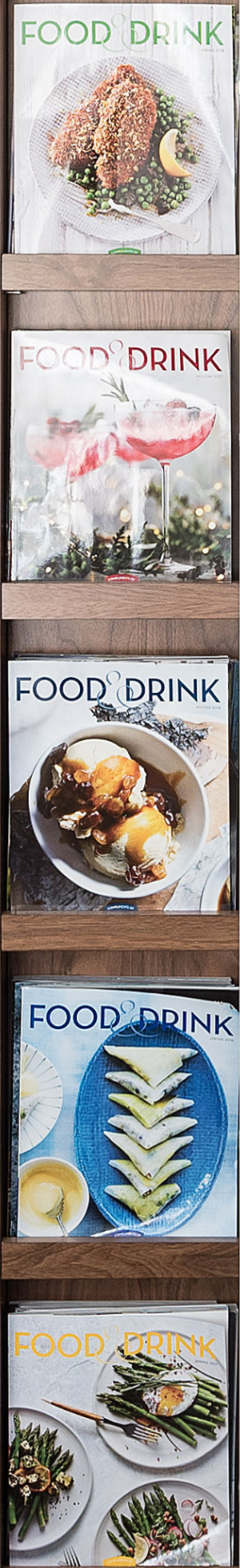

Give voice to every inch

INTERIOR FINISHES

NEFF's custom interior finishes highlight that which is often overlooked and manufactures the transformative.

1. Choose the interior lining of the drawer box:
Front, Back and Sides.

2. Select the drawer box bottom to match the front,
back and sides or optional Brushed Metal

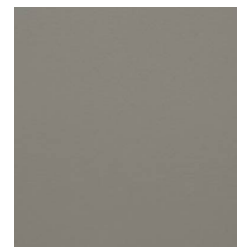
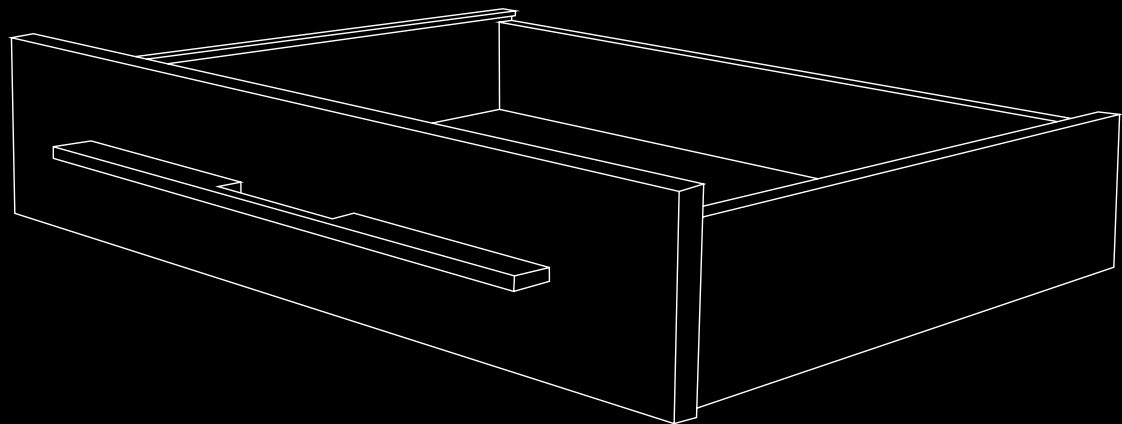

CUBANITE

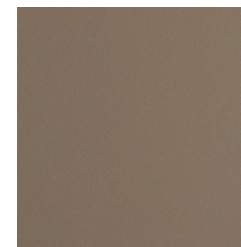

STONE

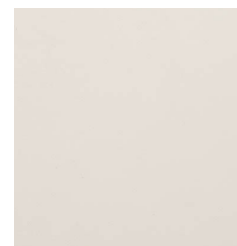

ICE WHITE



RHODIUM



PRE-FINISHED MAPLE
VENEER

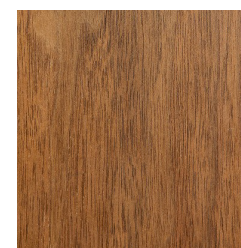

PRE-FINISHED WALNUT
VENEER



Beautiful by Nature

LEATHERS

A collection of genuine leather finishes delicately treated to take on a variety of hues, which complement and enhance the vision of fine décor.



Sleek & smooth.

Grand
Decadence



DASH



IVORY



LINEN



ASHPHALT



SIENA



GRAYSTONE



MOONSTONE



PUMA

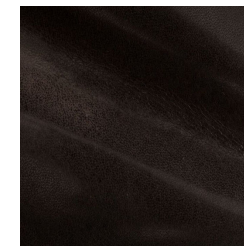

CACAO

LEATHERS /



Welding Perfection

MAKE IT METAL

Durable, contemporary and aesthetically vivid metals, each cultivated and brushed with unique finishes that bring and evoke new personalities.



SILKY SMOOTH BRASS



SILKY SMOOTH GOLD



SILKY SMOOTH BRONZE



BRASS BRUSHED PATINA



BRASS CORKBOARD



CASTED BRASS

METALS \



SMOKY GOLD

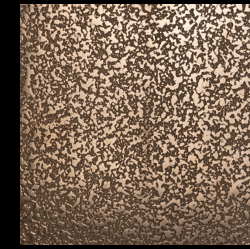

BRONZE ROCKY ROAD

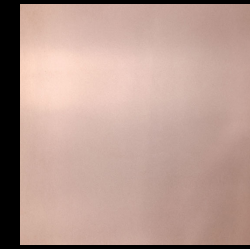

SILKY SMOOTH COPPER



SMOKY COPPER



CASTED BRONZE



SILKY SMOOTH IRON



SMOKY IRON



IRON BRUSHED PATINA

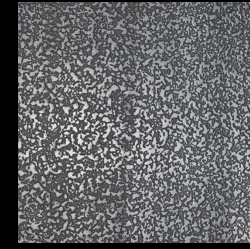

NICKEL SILVER ROCKY ROAD

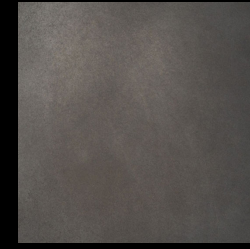

SMOKY WHITE BRONZE



Texture, pattern, shape in harmony

DOOR STYLES

NEFF's vast selection of door styles opens up infinite possibilities with the flexibility to customize your own.



STYLE 26

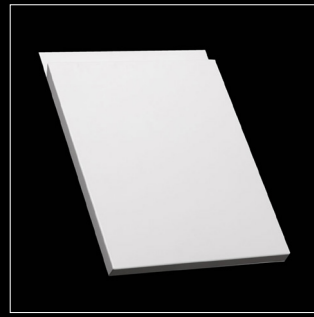

STYLE 27



STYLE 28



STYLE 29



STYLE 52



STYLE 53



STYLE 55



STYLE 56

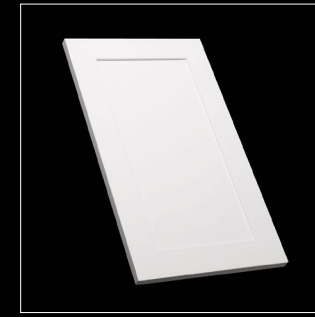

STYLE 31&32

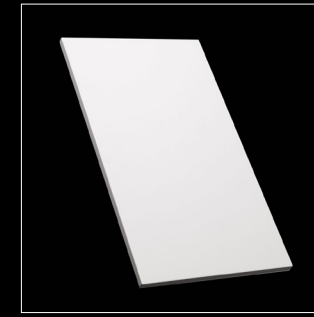

STYLE 35&37

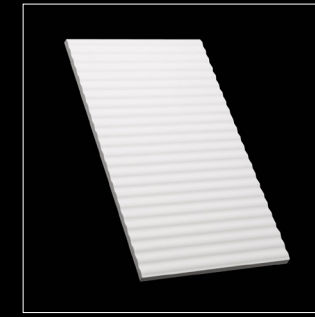

STYLE 43

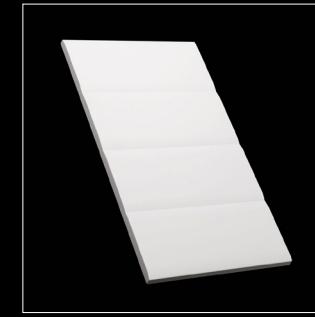

STYLE 51



STYLE 68



STYLE 74



STYLE 80



STYLE 81



STYLE 82



STYLE 83



STYLE 84

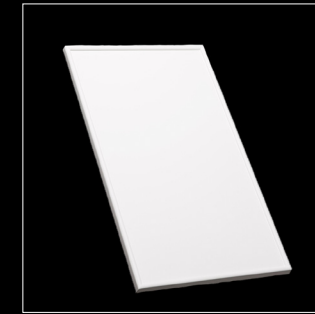

STYLE 87

DOOR STYLE \



Dessau Collection

HARDWARE

NEFF produces quality hardware varied in type, size, and color that meets the high standards of our own brand, complementing the existing design, down to the final details.

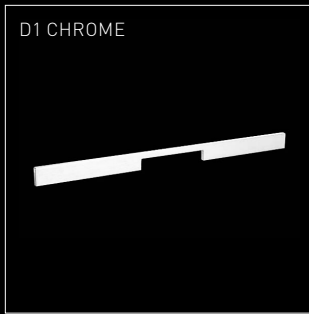

D1 CHROME

DESSAU, 45CM,
SYMMETRICAL HANDLE



D2 CHROME

DESSAU, 45CM,
ASYMMETRICAL HANDLE



D3 CHROME

DESSAU, 25.6CM,
SYMMETRICAL HANDLE



D4 CHROME

DESSAU, 25.6CM,
ASYMMETRICAL HANDLE

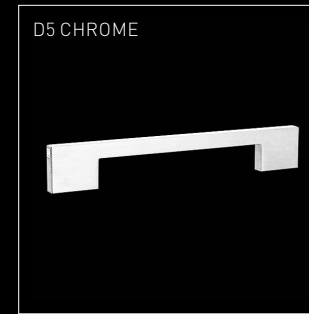

D5 CHROME

DESSAU, 17.3CM,
SYMMETRICAL HANDLE



D6 CHROME

DESSAU, 4.5CM, KNOB



D7 CHROME

DESSAU, 39CM,
APPLIANCE HANDLE

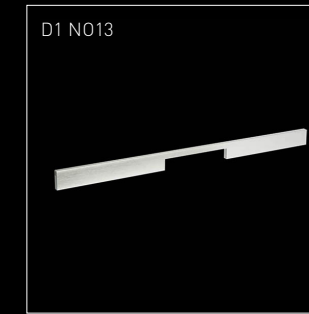

D1 N013

DESSAU, 45CM,
SYMMETRICAL HANDLE

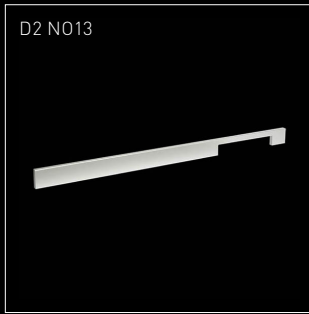

D2 N013

DESSAU, 45CM,
ASYMMETRICAL HANDLE



D3 N013

DESSAU, 25.6CM,
SYMMETRICAL HANDLE



D4 N013

DESSAU, 25.6CM,
ASYMMETRICAL HANDLE



D5 N013

DESSAU, 17.3CM,
SYMMETRICAL HANDLE

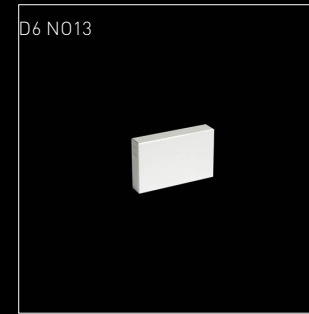

D6 N013

DESSAU, 4.5CM, KNOB



D7 N013

DESSAU, 39CM,
APPLIANCE HANDLE

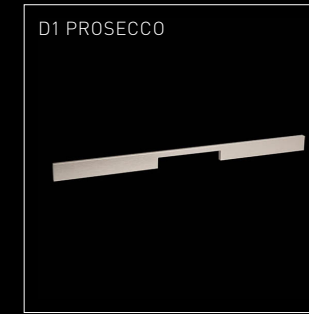

D1 PROSECCO

DESSAU, 45CM,
SYMMETRICAL HANDLE

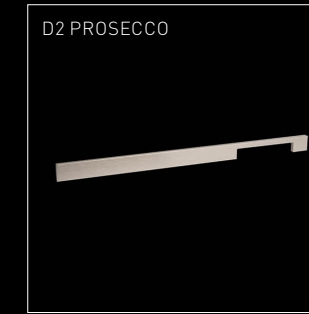

D2 PROSECCO

DESSAU, 45CM,
ASYMMETRICAL HANDLE

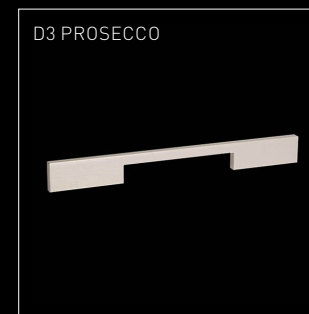

D3 PROSECCO

DESSAU, 25.6CM,
SYMMETRICAL HANDLE



D4 PROSECCO

DESSAU, 25.6CM,
ASYMMETRICAL HANDLE

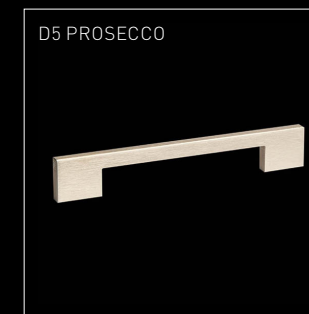

D5 PROSECCO

DESSAU, 17.3CM,
SYMMETRICAL HANDLE



D6 PROSECCO

DESSAU, 4.5CM, KNOB

HARDWARE \



D1 CHAMPAGNE

DESSAU, 45CM,
SYMMETRICAL HANDLE



D2 CHAMPAGNE

DESSAU, 45CM,
ASYMMETRICAL HANDLE



D3 CHAMPAGNE

DESSAU, 25.6CM,
SYMMETRICAL HANDLE



D4 CHAMPAGNE

DESSAU, 25.6CM,
ASYMMETRICAL HANDLE



D5 CHAMPAGNE

DESSAU, 17.3CM,
SYMMETRICAL HANDLE



D6 CHAMPAGNE

DESSAU, 4.5CM, KNOB



D7 CHAMPAGNE

DESSAU, 39CM,
APPLIANCE HANDLE



D1 BRONZATO

DESSAU, 45CM,
SYMMETRICAL HANDLE



D2 BRONZATO

DESSAU, 45CM,
ASYMMETRICAL HANDLE



D3 BRONZATO

DESSAU, 25.6CM,
SYMMETRICAL HANDLE



D4 BRONZATO

DESSAU, 25.6CM,
ASYMMETRICAL HANDLE



D5 BRONZATO

DESSAU, 17.3CM,
SYMMETRICAL HANDLE



D6 BRONZATO

DESSAU, 4.5CM, KNOB



D7 BRONZATO

DESSAU, 39CM,
APPLIANCE HANDLE

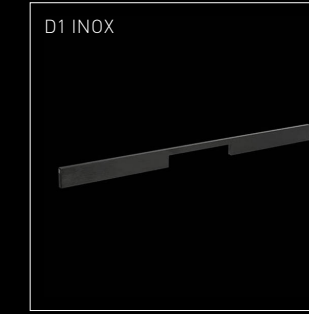

D1 INOX

DESSAU, 45CM,
SYMMETRICAL HANDLE

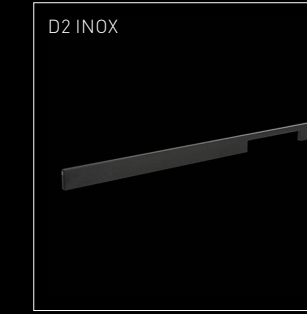

D2 INOX

DESSAU, 45CM,
ASYMMETRICAL HANDLE



D3 INOX

DESSAU, 25.6CM,
SYMMETRICAL HANDLE



D4 INOX

DESSAU, 25.6CM,
ASYMMETRICAL HANDLE



D5 INOX

DESSAU, 17.3CM,
SYMMETRICAL HANDLE

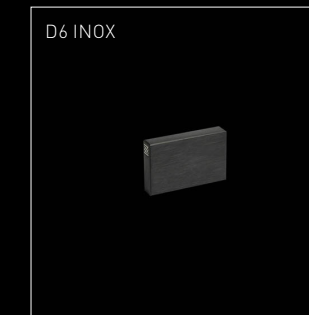

D6 INOX

DESSAU, 4.5CM, KNOB

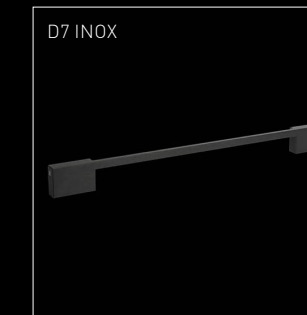

D7 INOX

DESSAU, 4.5CM, KNOB

HARDWARE \



The Living Creation

ACCESSORIES

NEFF's custom accessories and inserts are the finishing touches. Offering the top names in the industry, NEFF introduces these established relationships to the client. In the end, pieces of perfection will always find each other.



1 COMPARTMENT FRAME
FRAME 1-10, OAK
10CM W X 7 CM H X 50.6CM D,



1 COMPARTMENT FRAME
FRAME 1-20, OAK
20CM W X 7 CM H X 50.6CM D

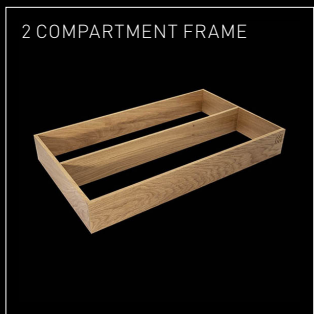

2 COMPARTMENT FRAME
FRAME 2-30, OAK
30CM W X 7 CM H X 50.6CM D

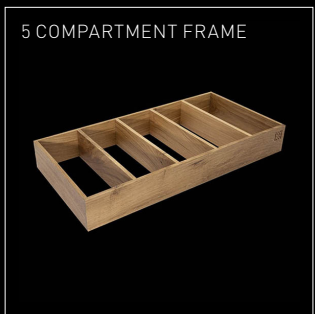

5 COMPARTMENT FRAME
FRAME 5-25, OAK
25CM W X 7 CM H X 50.6CM D



WRAP HOLDER (PAPER,
PLASTIC, FOIL)
WRAP 1-10, OAK
10CM W X 7 CM H X 50.6CM D



KNIFE ORGANIZER (5 KNIVES)
KNIFE 5-20, OAK
20CM W X 3.7 CM H X 50.6CM D

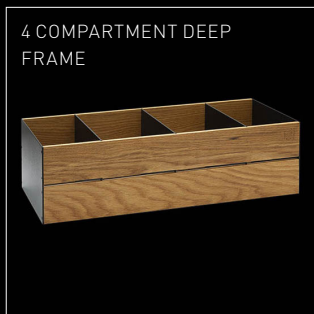

4 COMPARTMENT DEEP
FRAME
DEEPFRAME 4-20, OAK
20CM W X 14 CM H X 50.6CM D

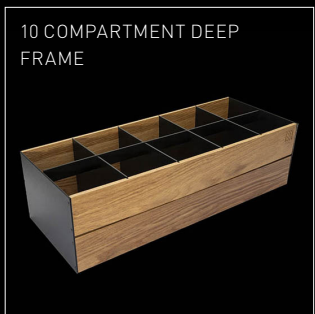

10 COMPARTMENT DEEP
FRAME
DEEPFRAME 10-20, OAK
20CM W X 14 CM H X 50.6CM D

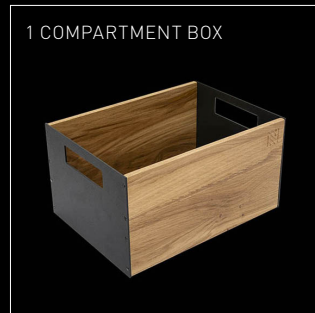

1 COMPARTMENT BOX
DEEPBOX 1-19, OAK
19CM W X 14 CM H X 26CM D



DIVIDER
DIVIDER-1, OAK
0.6CM W X 7 CM H X 50.6CM D

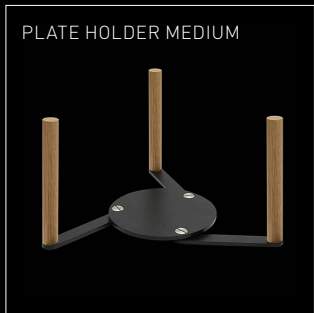

PLATE HOLDER MEDIUM
PLATE 1-M, OAK
14CM W X 15.5 CM H X 14CM D



1 COMPARTMENT FRAME
FRAME 1-10, WALNUT
10CM W X 7 CM H X 50.6CM D



1 COMPARTMENT FRAME
FRAME 1-20, WALNUT
20CM W X 7 CM H X 50.6CM D



2 COMPARTMENT FRAME
FRAME 2-30, WALNUT
30CM W X 7 CM H X 50.6CM D



5 COMPARTMENT FRAME
FRAME 5-25, WALNUT
25CM W X 7 CM H X 50.6CM D



WRAP HOLDER (PAPER,
PLASTIC, FOIL)
WRAP 1-10, WALNUT
10CM W X 7 CM H X 50.6CM D

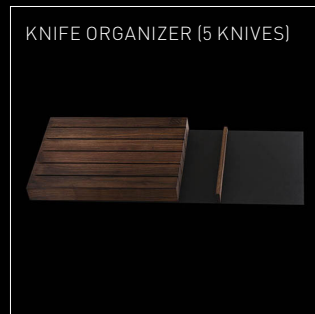

KNIFE ORGANIZER (5 KNIVES)
KNIFE 5-20, WALNUT
20CM W X 3.7 CM H X 50.6CM D

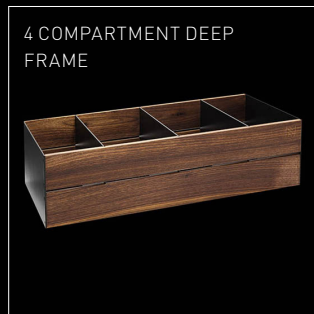

4 COMPARTMENT DEEP
FRAME
DEEPFRAME 4-20, WALNUT
20CM W X 14 CM H X 50.6CM D

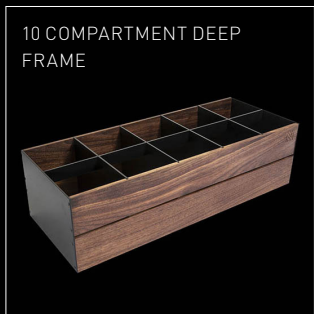

10 COMPARTMENT DEEP
FRAME
DEEPFRAME 10-20, WALNUT
20CM W X 14 CM H X 50.6CM D

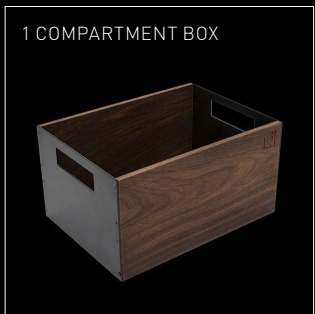

1 COMPARTMENT BOX
DEEPBOX 1-19, WALNUT
19CM W X 14 CM H X 26CM D



DIVIDER
DIVIDER-1, WALNUT
0.6CM W X 7 CM H X 50.6CM D



DISH PEG INSERT
DISHPEG-1, WALNUT
4.6CM W X 15.2 CM H X 4.6CM D

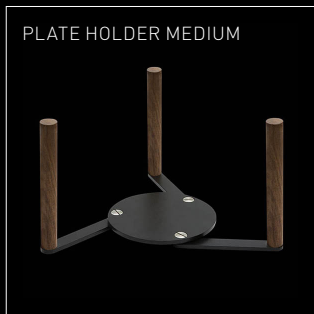

PLATE HOLDER MEDIUM
PLATE 1-M, WALNUT
14CM W X 15.5 CM H X 14CM D

ACCESSORIES \



Designed for life.

SPECIFICATIONS

Crafted to the highest standards, every detail meets the mark of excellence
— from premium materials to precision engineering.

THE NEFF DIFFERENCE

Construction

European Frameless, with full overlay doors/drawer fronts, NEFF has a unique approach to construction. Our panel system attaches sections of varying thickness to exposed cabinets ends and provide a furniture quality fit and finish.

Steel Conformat screws (dowels) with no glue/staples are used in assembly, and full top and bottom weight bearing with sides (gables)

between provides the ultimate in strength and structural integrity (ideal for carrying the load of heavy countertops).

Owing to the screwed construction, cabinet boxes can be easily disassembled, modified (on-site obstacles/pipe chases, etc.) and re-assembled, staying square during delivery and installation.

Cabinet Interiors

All plywood, 3/4" Baltic Birch (layers running lengthwise and crosswise bonded with very low VOC/98% formaldehyde free phenolic resin). A recessed 1/2" full height back panel (recessed back with hanging brackets to accommodate a hanging rail*).

Fixed and adjustable shelves are stacked 3/4" thick, with tight and consistent 1/8" (3mm) reveals/spaces between all doors/drawer fronts allowing for bind free opening/closing of all facings and a very high-end, sleek look.

*Optional hanging rail facilitates expedited leveling/ assembling of Upper cabinets.



Concealed Hinges

Blum, Soft-close, 6-way adjustability, attached directly to cabinet gables/walls.

Adjustable Cabinet Levelers

Easily adjustable up/down from the standard of 4" (102mm).

Drawer Box and Slides

NEFF exclusive, Metal or dovetail wood. Slides are premium Blum, steel, side mounted, full extension, featuring Blumotion soft-close. Side to side, up/down, front/back adjustability.

Patented Dry-Fit Process

Installs, fully assembles and stages the cabinet boxes into NEFF's custom-built staging areas ensure functionality and precision.



NEFF Plywood with Pre-Finished Veneer

- 3/4" (19mm) Pre Finished Maple or Walnut Plywood base, top, sides
- 1/2" (12mm) Pre Finished Maple or Walnut Plywood back
- Screwed base construction

BOX



NEFF Plywood with Vinyl Interiors

- 3/4" (19mm) Baltic Water Resistant Plywood base, top, sides
- 1/2" (12mm) Baltic Water Resistant Plywood back
- Screwed base construction



NEFF Metal

- 5/8" (16mm) Baltic Birch Water Resistant Plywood Base
- 1/2" (12mm) Baltic Birch Water Resistant Plywood Sides and Back
- Prefinished Anodized or Painted Aluminum Sides
- Screwed Construction

DRAWER



NEFF Wood

- 5/8" (16mm) Prefinished Maple / Walnut Plywood Base
- 1/2" (12mm) Prefinished Maple / Walnut Plywood Sides and Back
- Screwed Construction
- Screwed base construction

Dovetail

- Solid Maple or Walnut Dovetailed



Pantry

Custom crafted to blend in seamlessly with your kitchen design.



DOOR



Natural Veneer Cladding with choice of Finishes

- UNO technology performs and exceeds to American Architectural Manufacturers Association's publication numbers.
- UNO HD can produce varying degrees of gloss. Custom colours are available in both conventional and Low VOC options.
- Offers heat management coatings using special pigment technology. This reduces heat absorption in dark colours and lowers surface temperature strain, providing coatings with longer service life.
- Recommended for use on prepared aluminum, steel, plastics and composite substrates.

BASF Automotive Paint

- UNO technology performs and exceeds to American Architectural Manufacturers Association's publication numbers.
- UNO HD can produce varying degrees of gloss. Custom colours are available in both conventional and Low VOC options.
- Offers heat management coatings using special pigment technology. This reduces heat absorption in dark colours and lowers surface temperature strain, providing coatings with longer service life.
- Recommended for use on prepared aluminum, steel, plastics and composite substrates.
- Along with its full palette, NEFF offers bespoke colours and the ability to colour match any custom paint. Baked on through a resoundingly integrative process, we only use BASF automobile paint, the very same ones used on Bentleys and private jets. They are durable, easy to clean and of the finest quality—finished in matte, silk or high-gloss.



Painted

- Platinum Grade 3/4" - 1" (19mm - 25mm) MDF

Veneer

- Platinum Grade 3/4" - 1" (19mm - 25mm) MDF

Euro-Laminate

- 3/4" (19mm) Eurolaminate

CABINETS

Flush inset



Full overlay

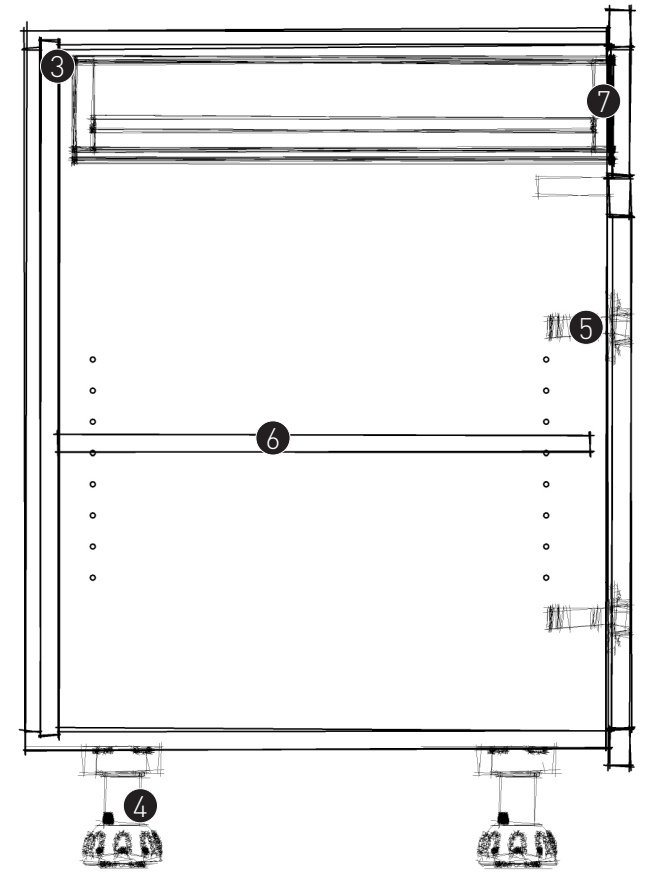

1	3/4" Baltic birch plywood
2	1/8" (3mm) reveals
3	Recessed 1/2" full height back panel
4	Adjustable cabinet levelers
5	3/4" fixed and adjustable shelves
6	Concealed Blum Soft-Close Hinges
7	NEFF Metal or dovetail wood drawer boxes and Blumotion soft-close slides

Experience The

PERFECT APPROACH.



NEFF's departments are staffed by industry specialists who use proven techniques and focus on detail, driven by a culture of continuous improvement. Their automated systems and patented dry-fit process, monitored by a Staging Completion Checklist, ensure precision and accountability in product installation.



The Staging Completion Checklist involves a thorough review by stagers, technicians, and design experts to verify that dimensions, finishes, functionality, and accessories meet NEFF's high standards before proceeding to the next stage.



The checklist, signed by all involved, spans from design to installation, with any concerns or notes documented for the installer to address when setting up the product in the client's space.

A large, stylized number '8' is centered on the page, rendered in a dark gray color. The '8' is composed of two thick, curved lines that meet at the top and bottom, creating a central void. The background is solid black.

8-YEAR LIMITED WARRANTY

Product Guaranteed

*Timely Repair
& Replacing*

*Artisans
& Innovators*

Crafted to the highest standards and built to last. Our skilled team of artisans and innovators follow along through every step of the process to ensure perfection from start to finish.

